



Universal Asynchronous Receiver Transmitter

8250/14550/16550/16550A

Walter Fetter Lages

w.fetter@ieee.org

Universidade Federal do Rio Grande do Sul

Escola de Engenharia

Departamento de Engenharia Elétrica

Microprocessadores II



Comunicação Serial

- Modo Simplex
- Modo Duplex
- Modo Half-duplex

Transmissão Síncrona

- Transmissão síncrona
 - Um bit transmitido a cada pulso de clock
 - Caracteres *back-to-back*

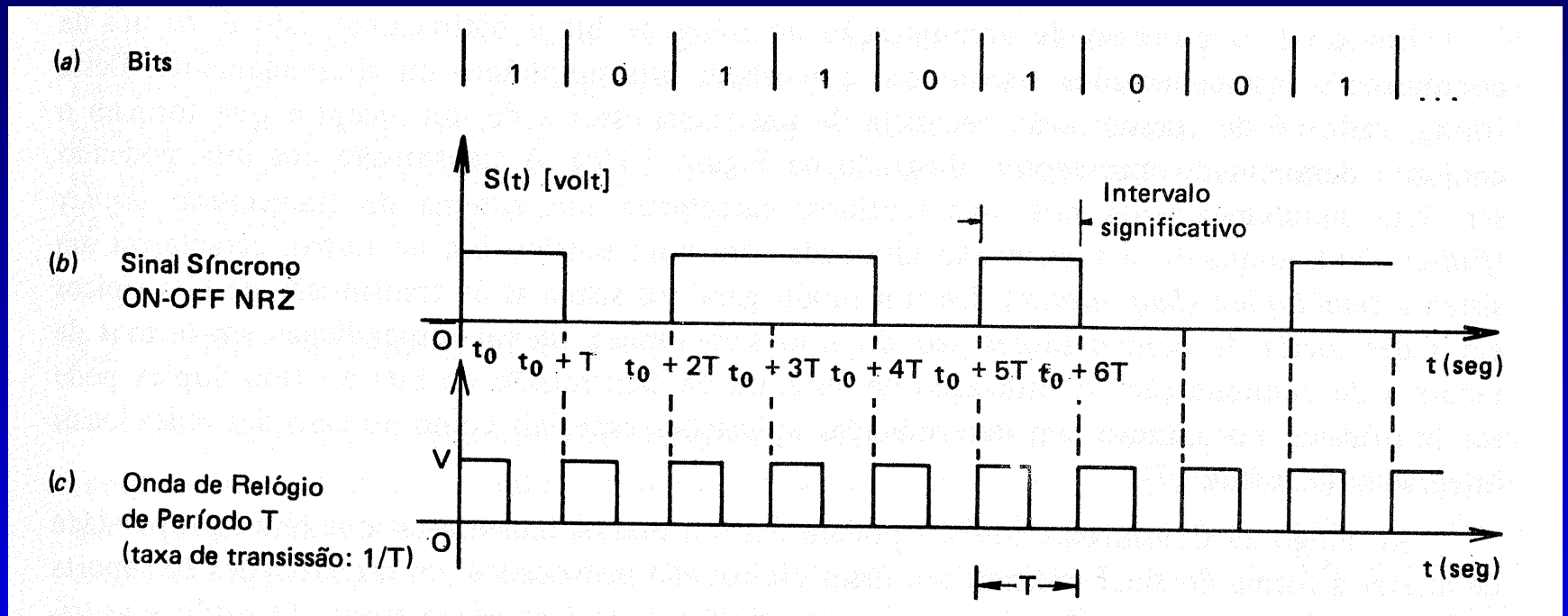

Transmissão Assíncrona

- Transmissão assíncrona
 - Utiliza Start bit para sinalizar o início de cada caracter

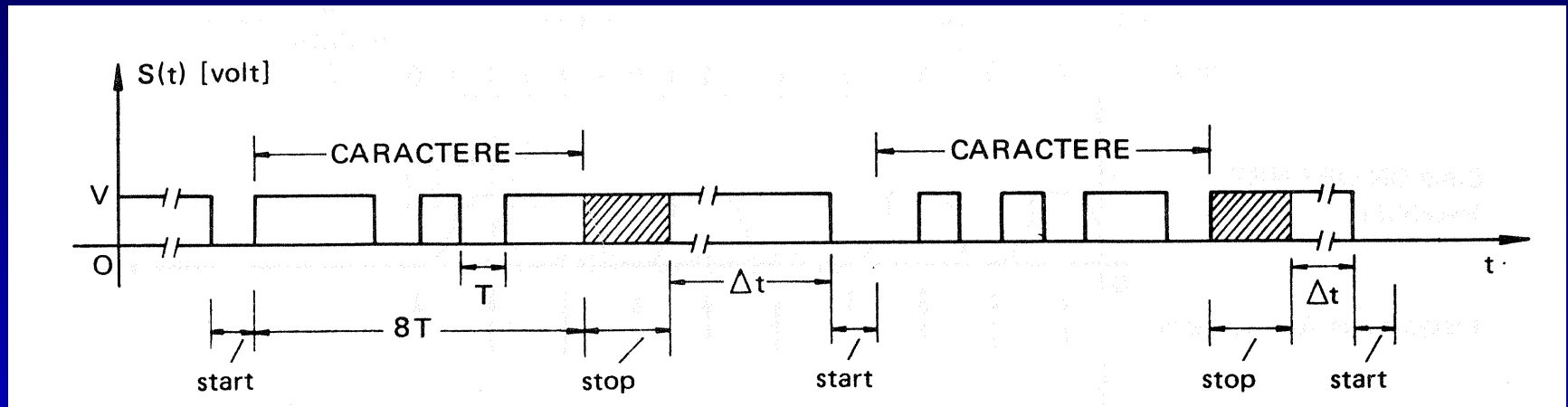



Codificação de Bits

- Banda básica
 - Sinal digital não modulado
- Banda estreita
 - Sinal analógico modulado pelo sinal digital
- Banda larga
 - Sinal analógico modulado pelo sinal digital



Codificação em Banda Básica

- On-off
- NRZ polar
- RZ unipolar
- Manchester
- Bifase
- Manchester diferencial
- Bifase diferencial
- Miller
- CMI



Codificação em Banda Básica

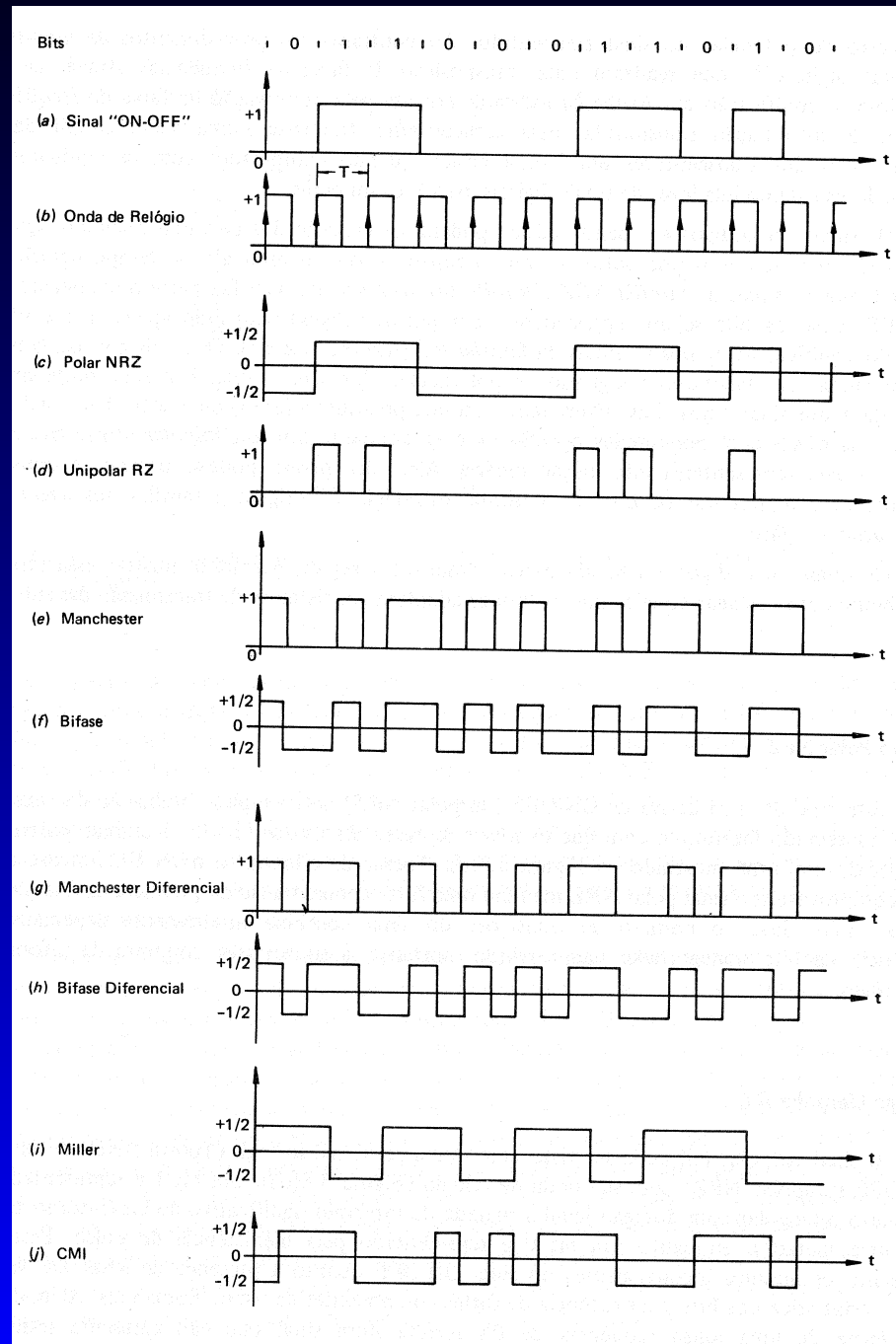



Modulação

- Alteração de uma ou mais características (amplitude, fase, frequência, ...) de um sinal (portadora) segundo um outro sinal (modulante)
- Modulação contínua
 - Portadora analógica
 - Modulante analógico
- Modulação de pulso
 - Portadora digital
 - Modulante analógico
- Modulação Digital
 - Portadora analógica
 - Modulante digital



Modulação Contínua

- Modulação em amplitude (AM)
- Modulação em fase (PM)
- Modulação em frequência (FM)

Modulação em Amplitude (AM)

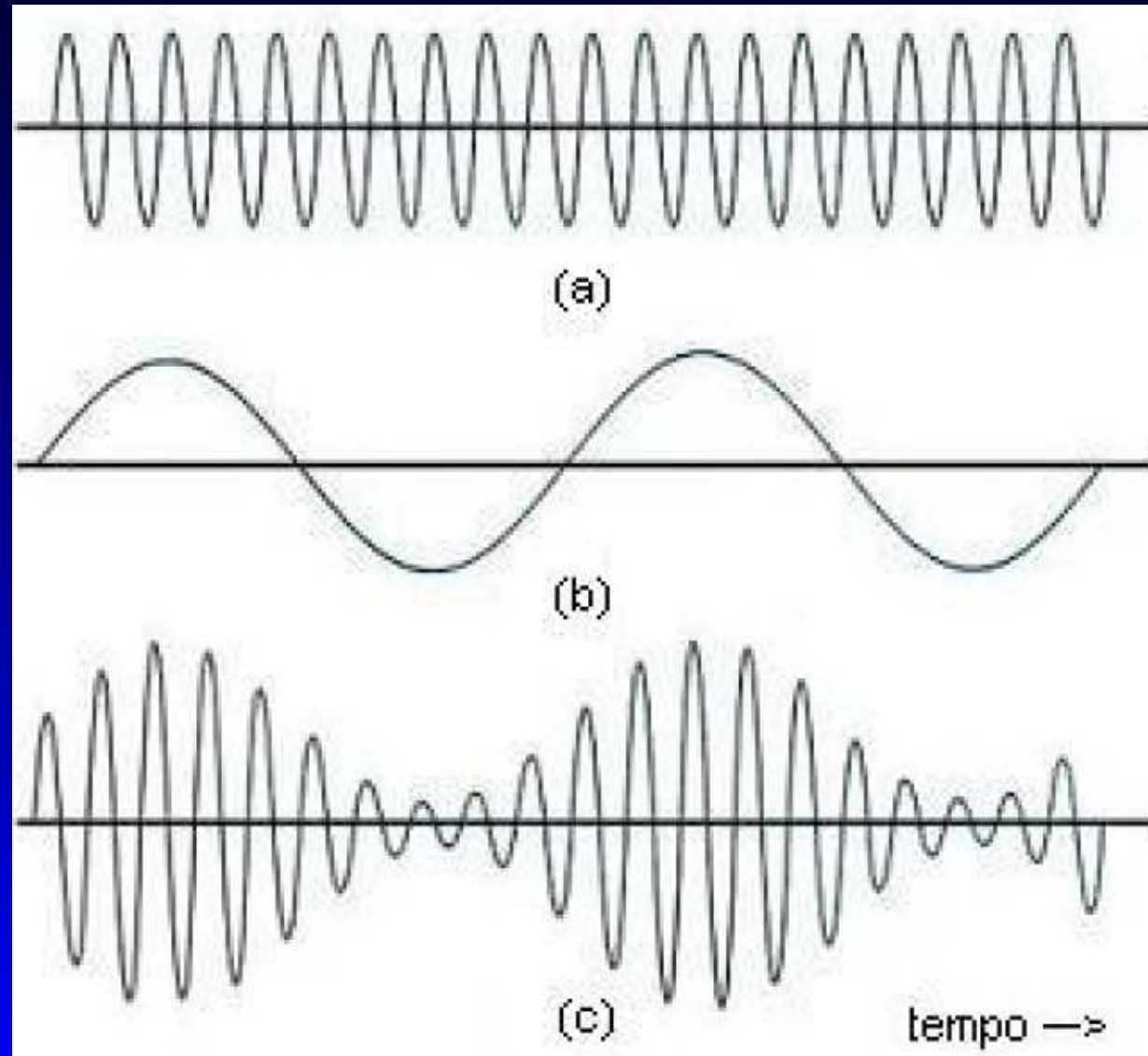

Modulação em Fase ou Frequência

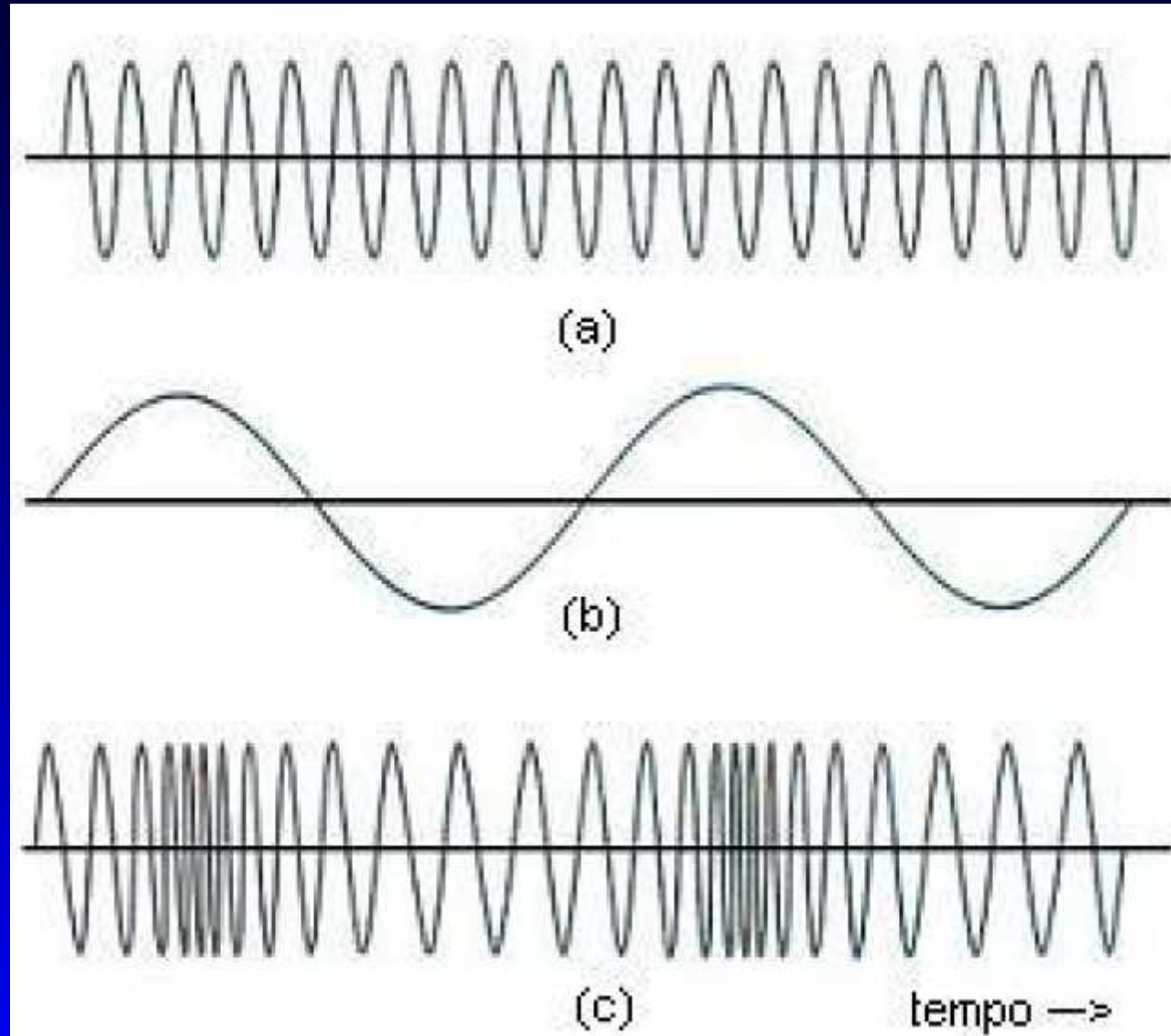



Modulação de Pulso

- Modulação de código de pulso (PCM)
- Modulação de amplitude de pulso (PAM)
- Modulação de largura de pulso (PWM)
- Modulação de posição de pulso (PPM)

Modulação de Amplitude de Pulso

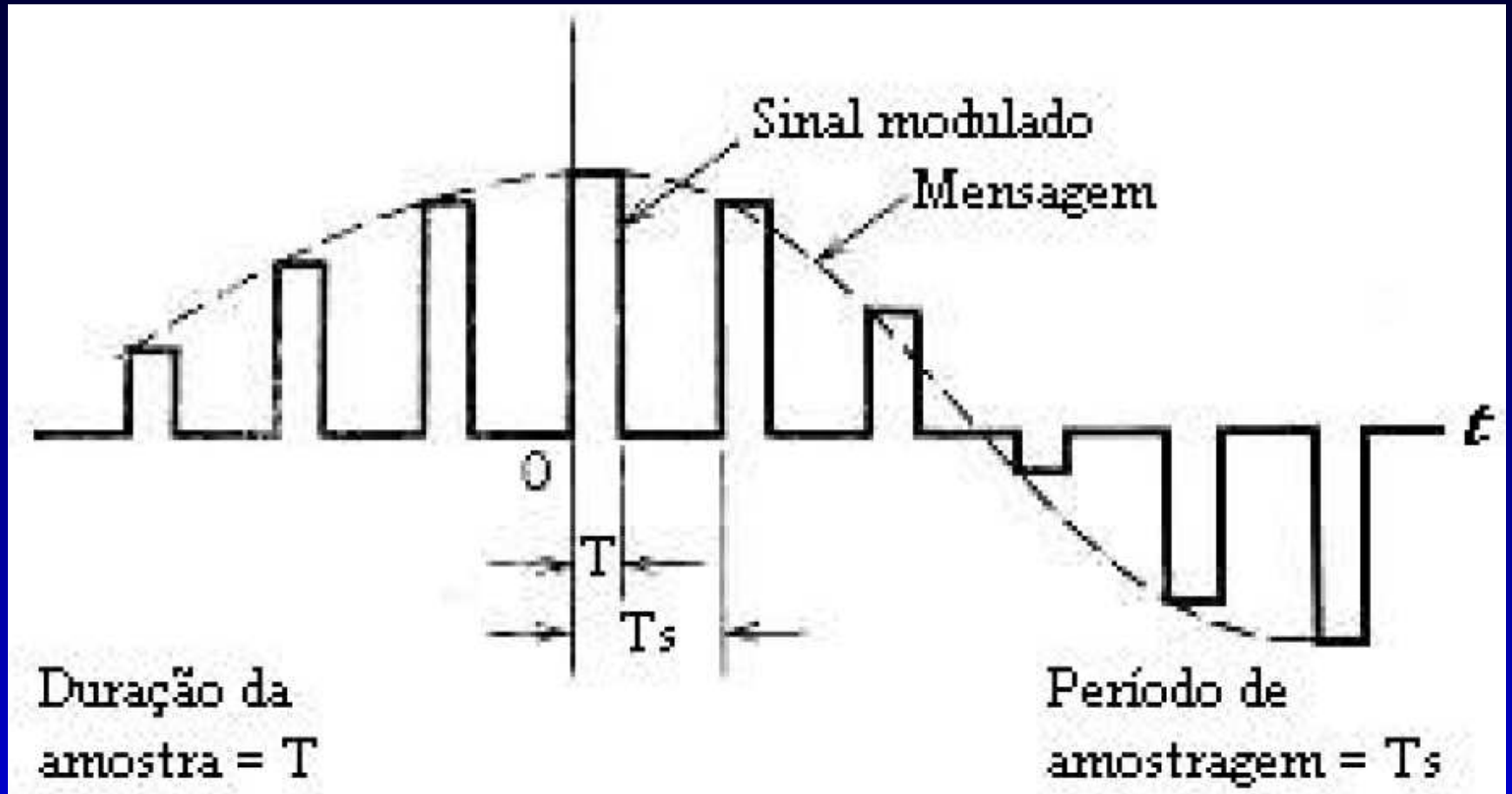



Modulação Digital

- Modulação por chaveamento de amplitude (ASK)
- Modulação por chaveamento de frequência (FSK)
- Modulação por chaveamento de fase (PSK)
- Modulação em amplitude e quadratura (QAM)



ASK, FSK, PSK

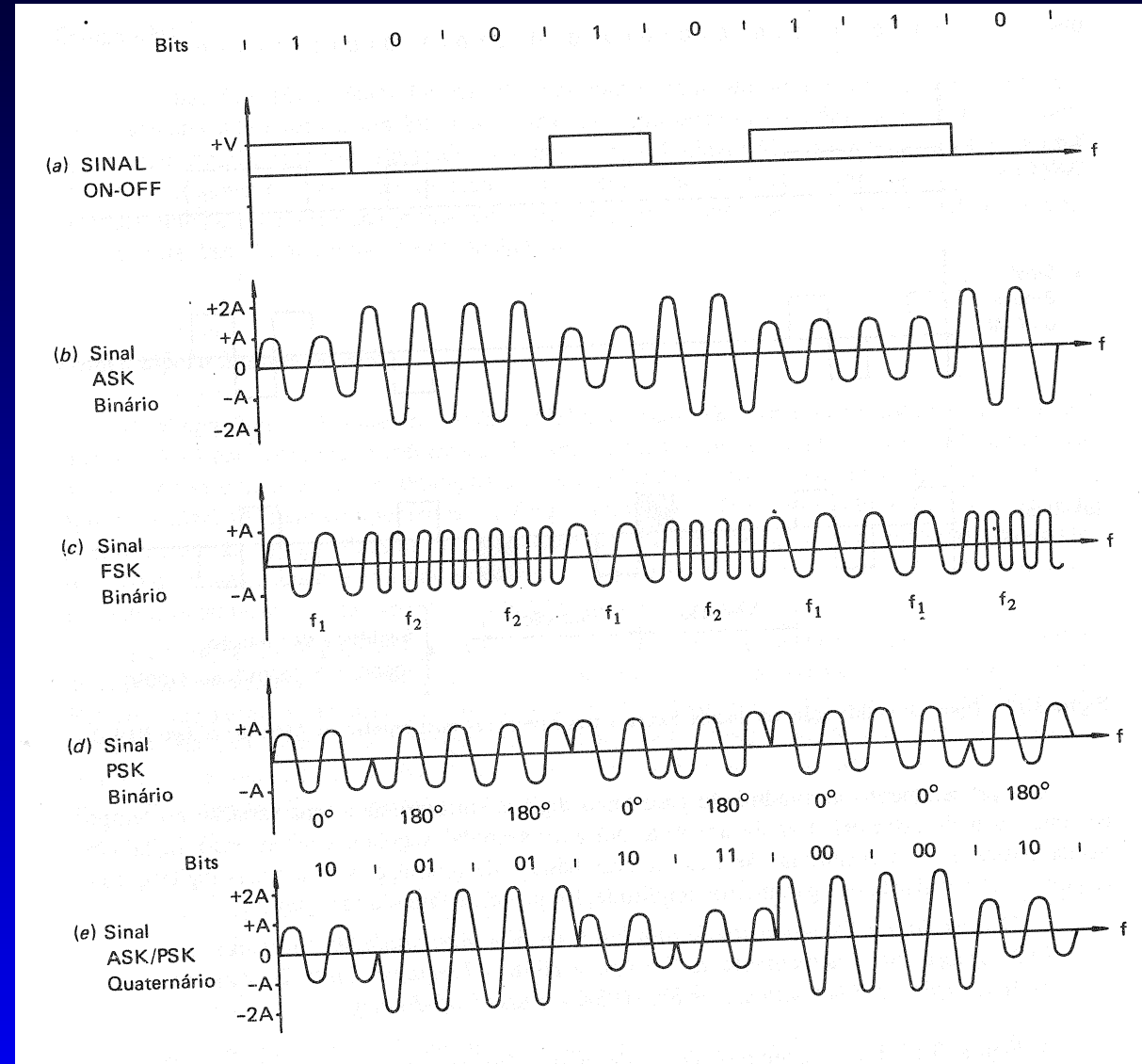

QAM

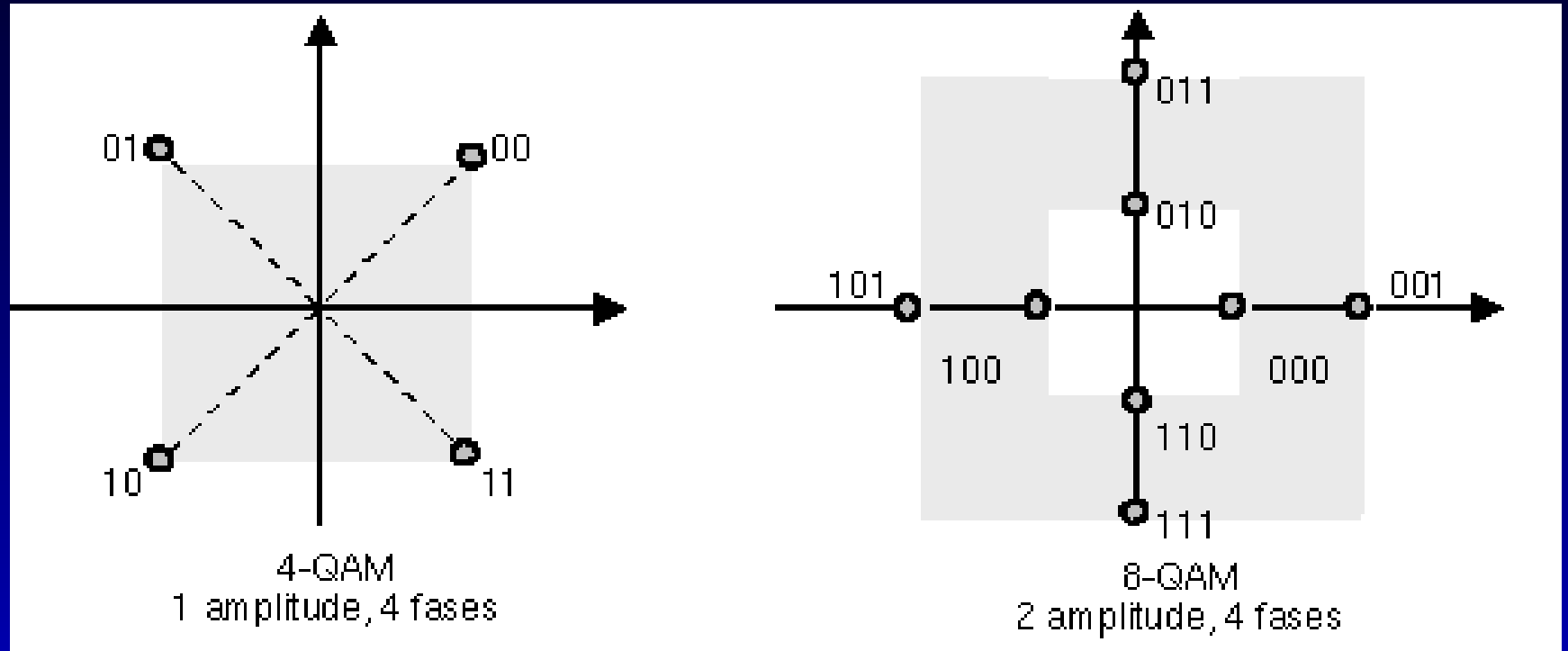



Taxa de Comunicação

- Taxa de informação
 - Quantidade bits transmitidos por segundo
 - Medido em bps
- Taxa de símbolos ou taxa de sinalização
 - Quantidade de sinais transmitidos por segundo
 - Medido em Bauds
 - Um símbolo pode corresponder 1, mais ou menos bits
- Baud \neq bps



RS-232

- Sinal bipolar
 - -3V a -15V marca +3V a +15V espaço
- Comunicação DTE-DCE serial até 20m

DTE: Data Terminal Equipment, tipicamente um computador

DCE: Data Communication Equipment, tipicamente um modem
- Taxas de até 19200bps
- Extensões para até 1.6Mbps



Sinais

TD: Transmissão de dados

RD: Recepção de dados

DTR: DTE pronto

DSR: DSE pronto

RTS: Pedido para transmitir

CTS: Autorização para transmitir

DCD: Portadora detectada

RI: Indicação de chamada



Conectores

- Originalmente a RS-232 especificava conectores DB-25
- DTE utiliza conector macho
- DCE utiliza conector fêmea
- O PC implementa apenas 9 dos sinais da RS-232
 - Passou-se a utilizar DB-9, que foi padronizado posteriormente
- Equipamentos podem emular DTE ou DCE
- Não é raro equipamentos emulando DTE utilizarem conector fêmea e vice-versa

Conector DB-25 (exemplo DTE)

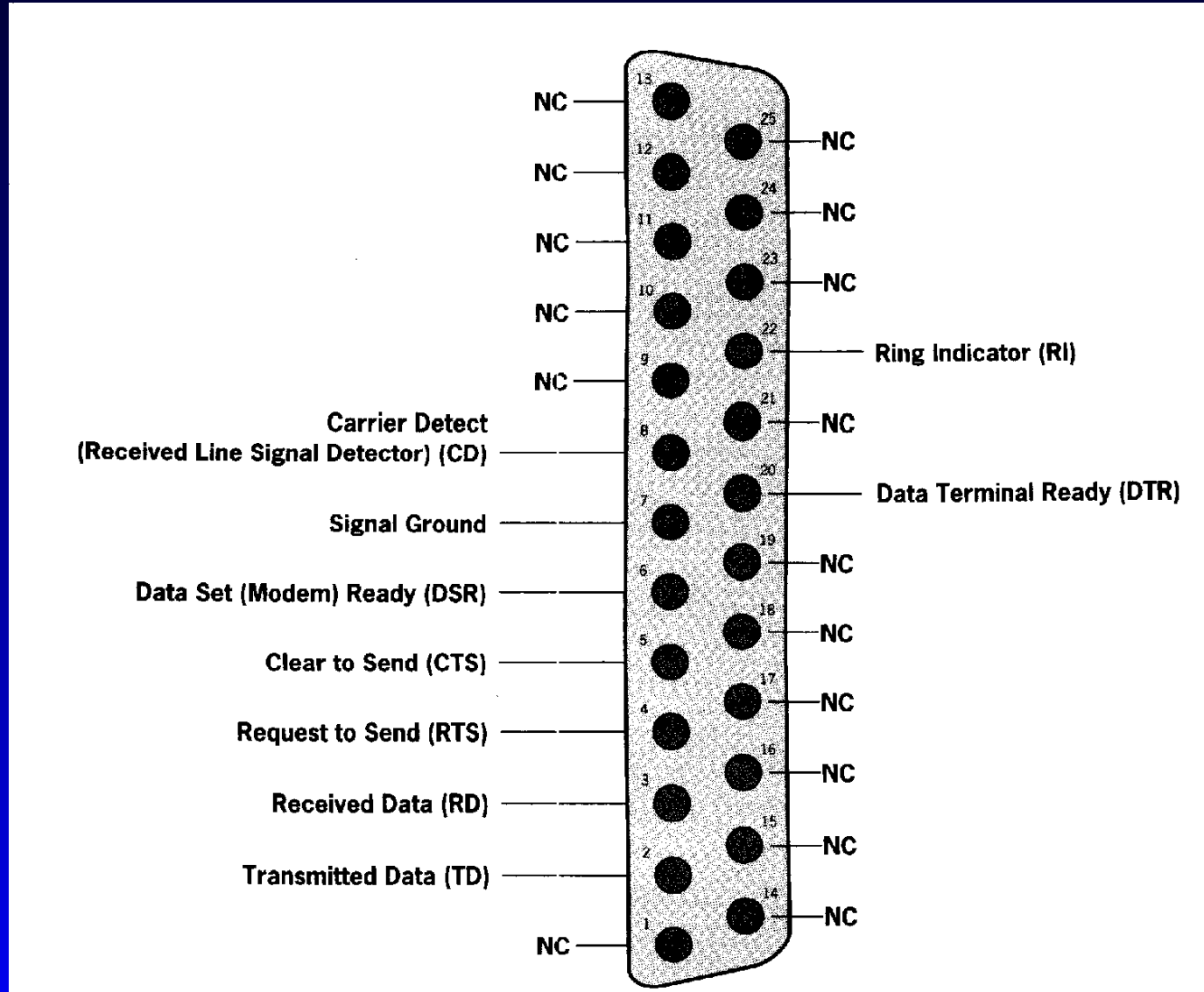

Conector DB-9 (exemplo DCE)

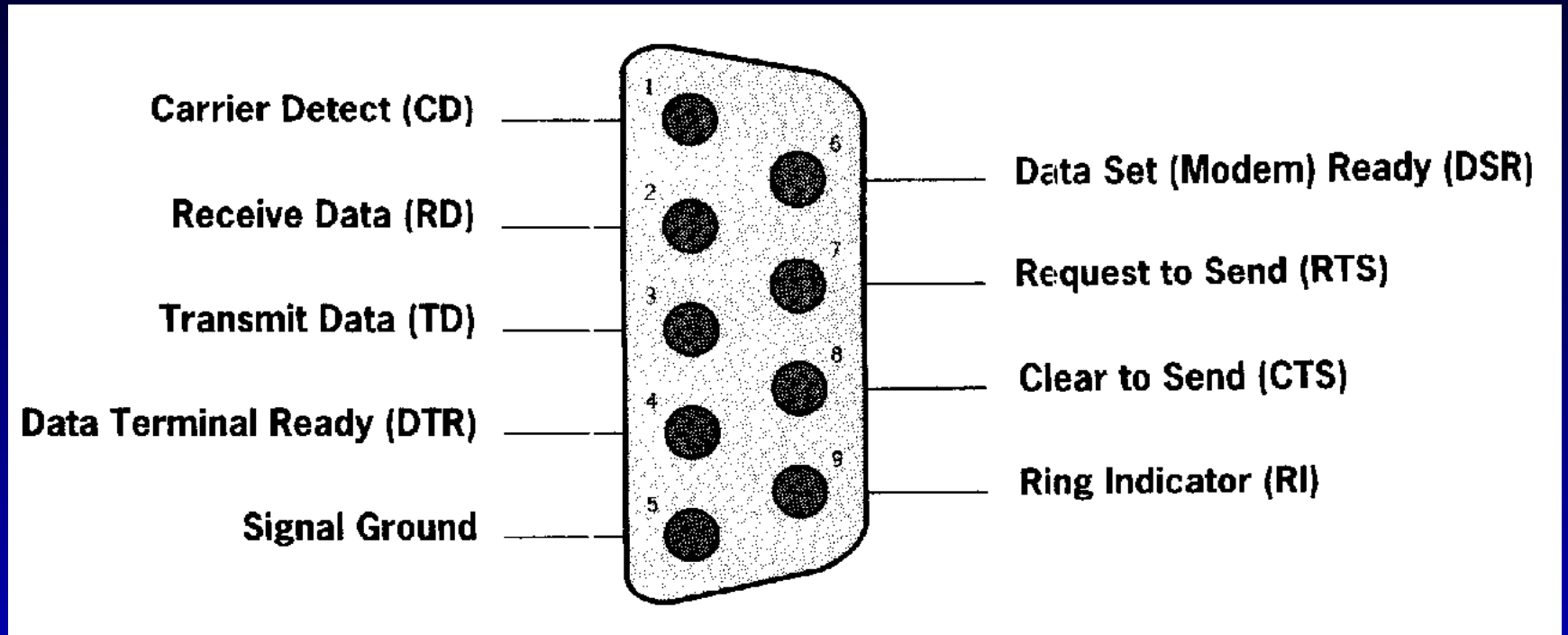

Handshaking

- Por software
 - X-ON= \hat{S} =11h
 - X-OFF= \hat{Q} =13h

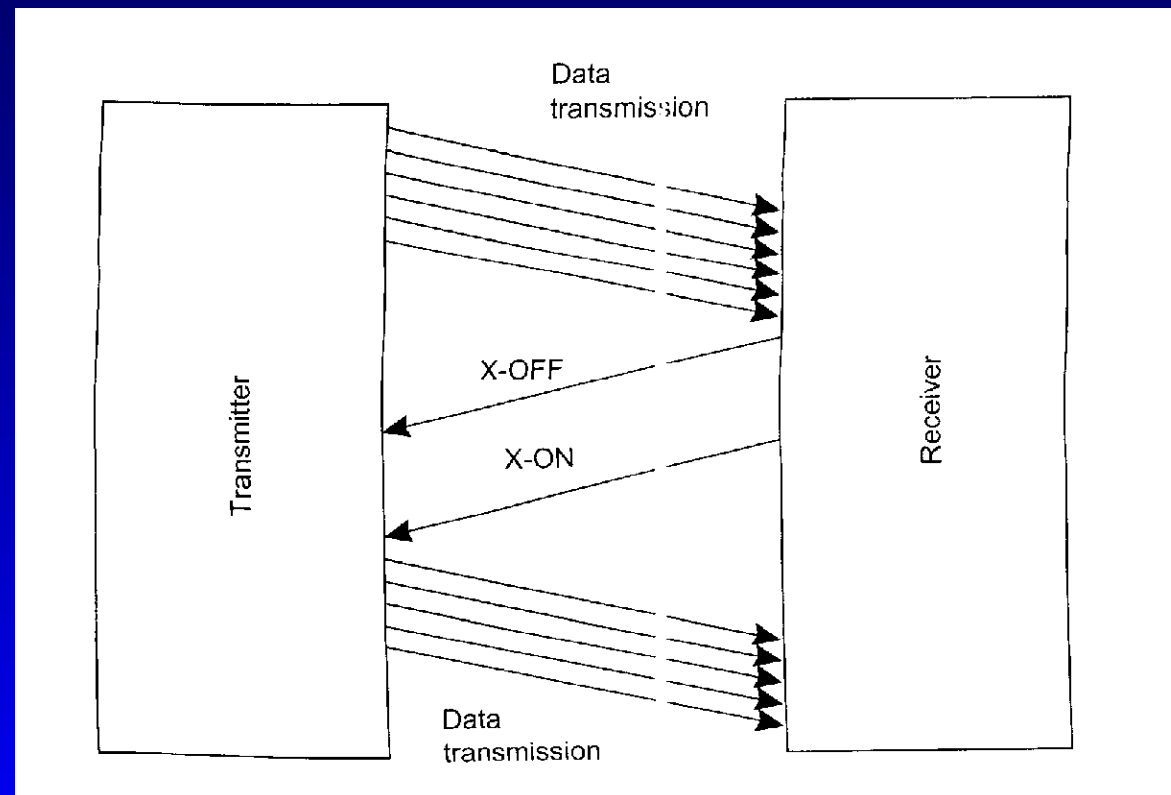

Handshaking

- Por hardware
 - RTS/CTS
 - DSR/DTR

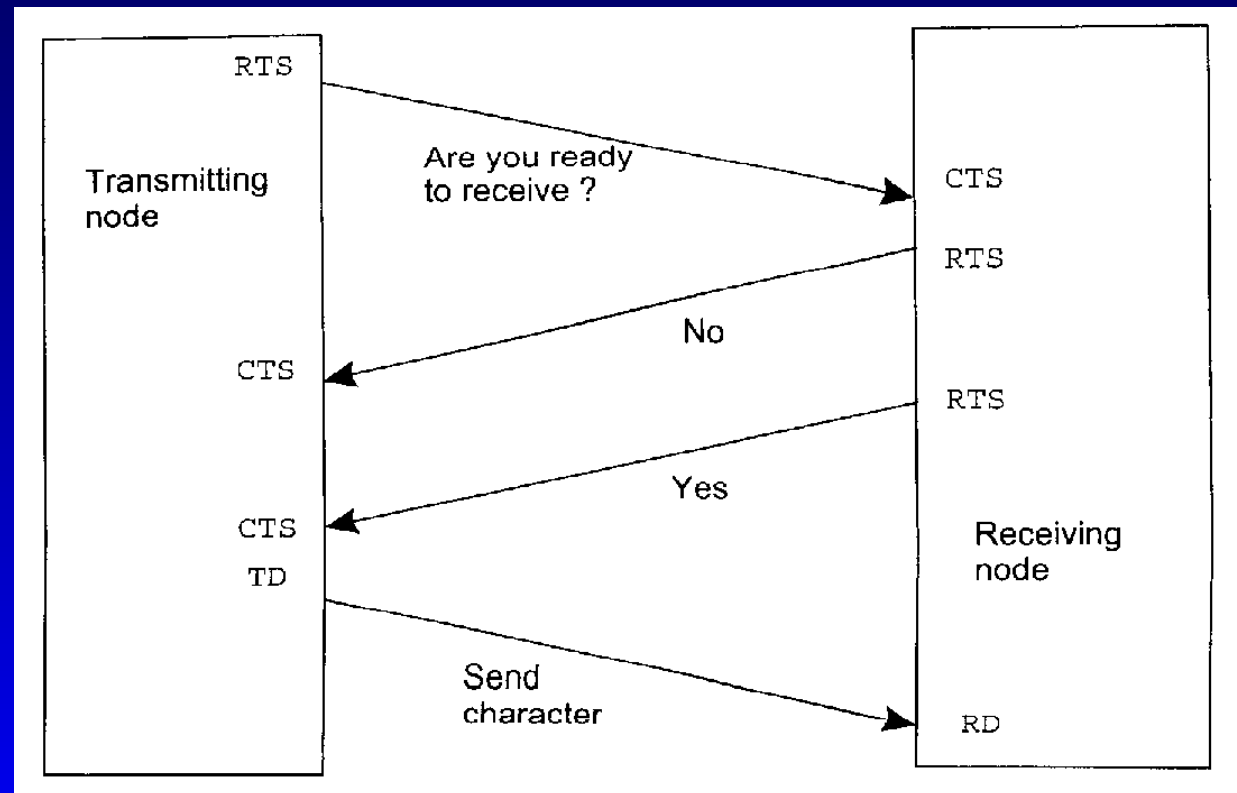

Cabeamento DTE-DCE

- *Handshaking completo*

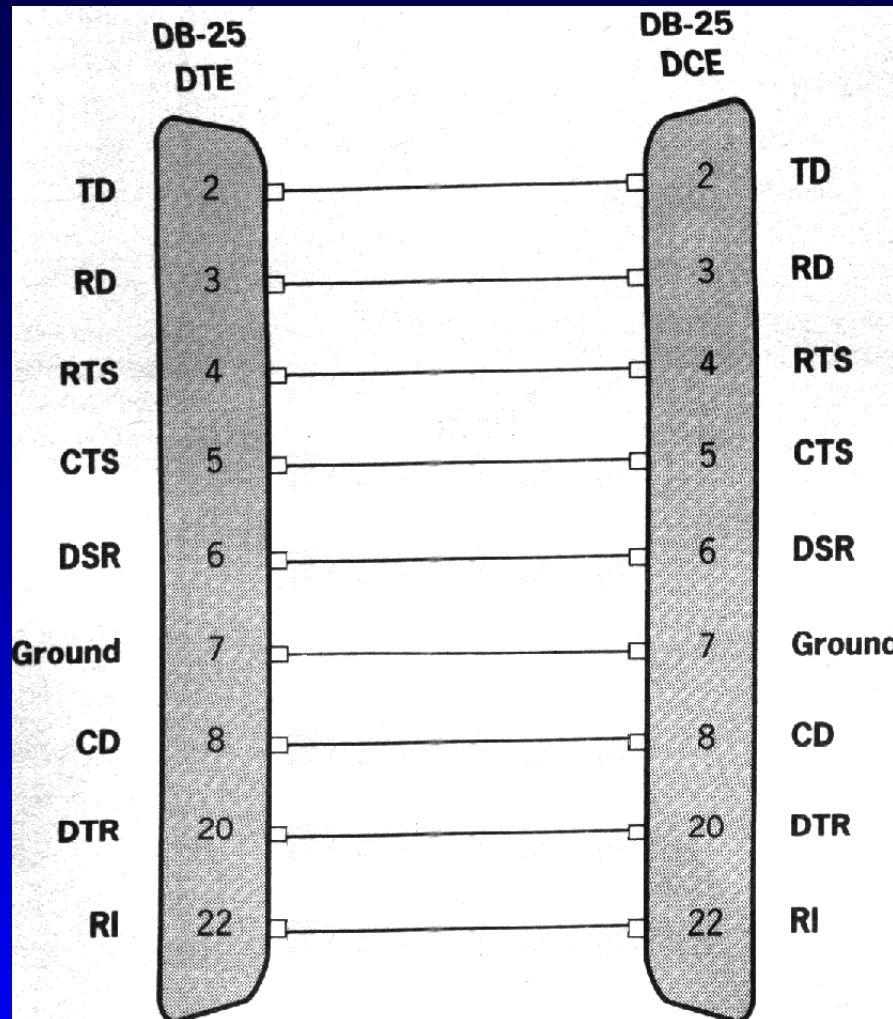



Cabeamento DTE-DCE

- Sem *handshaking*

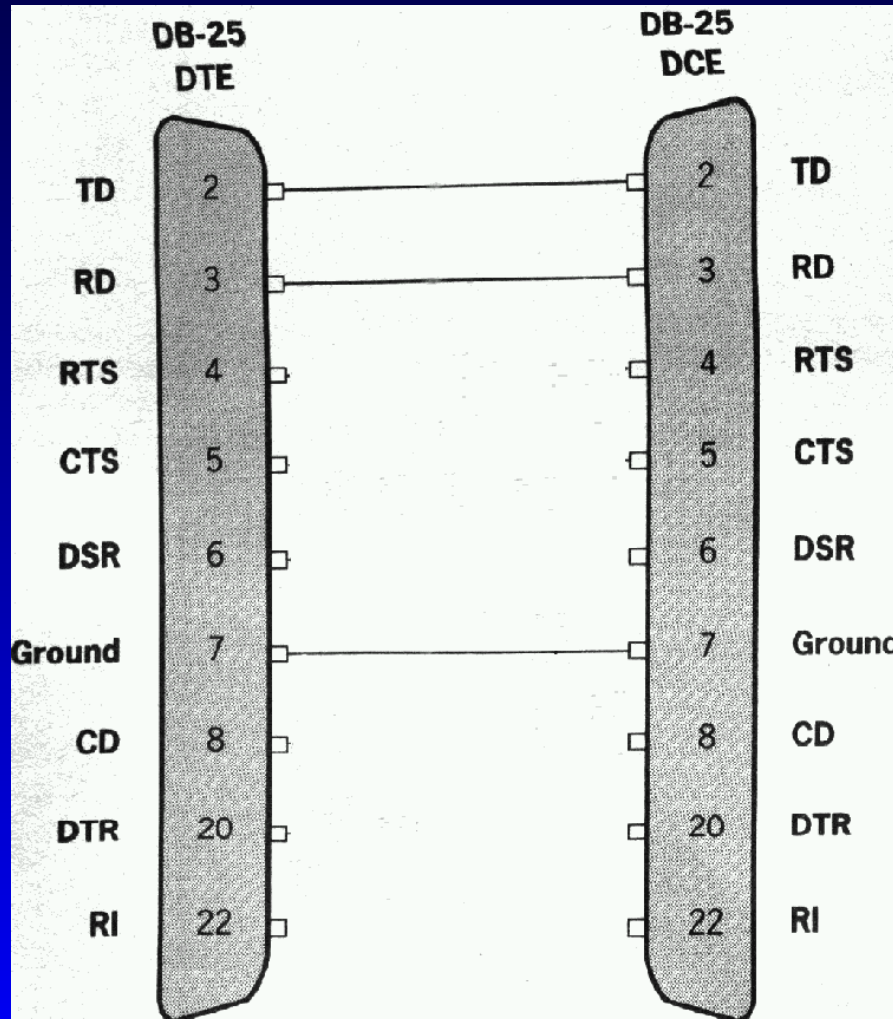

Cabeamento DTE-DCE

- RTS/CTS e DSR/DTR local

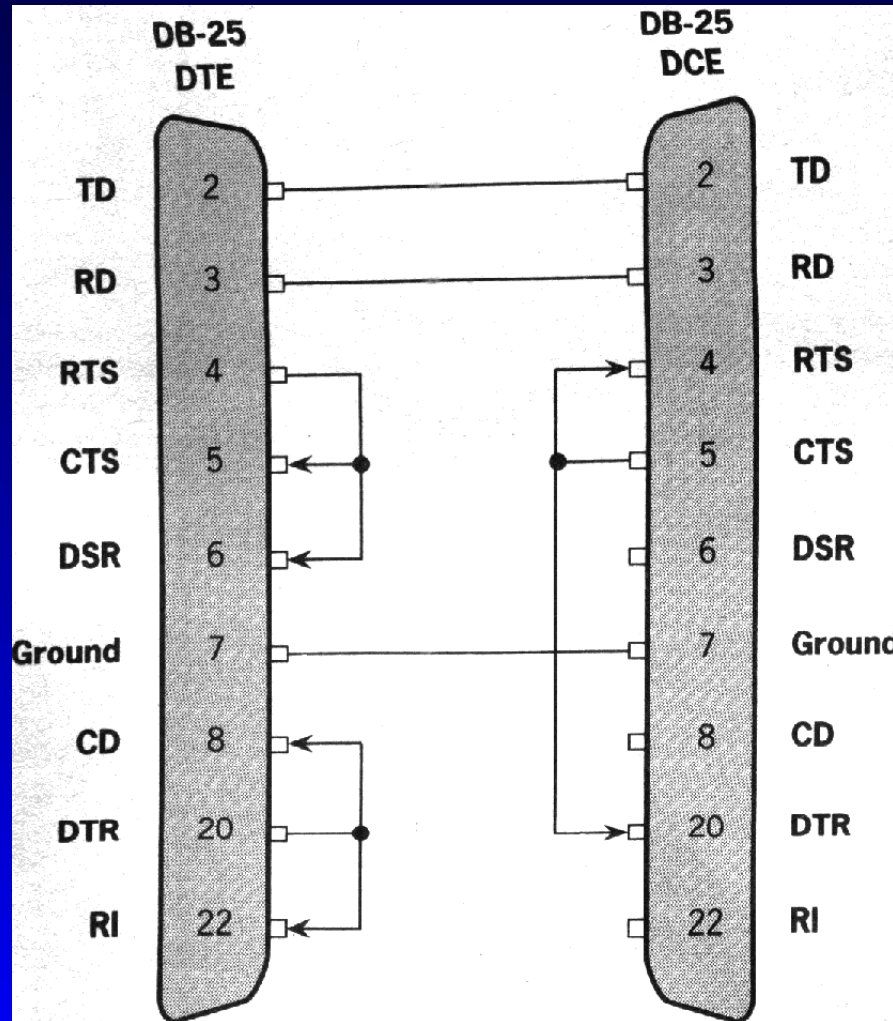

Cabeamento DTE-DTE

- Null-modem a três fios
 - Sem handshaking
 - RTS/CTS e DSR/DTR conectados localmente
- Null-modem a cinco fios
- Null-modem a sete fios

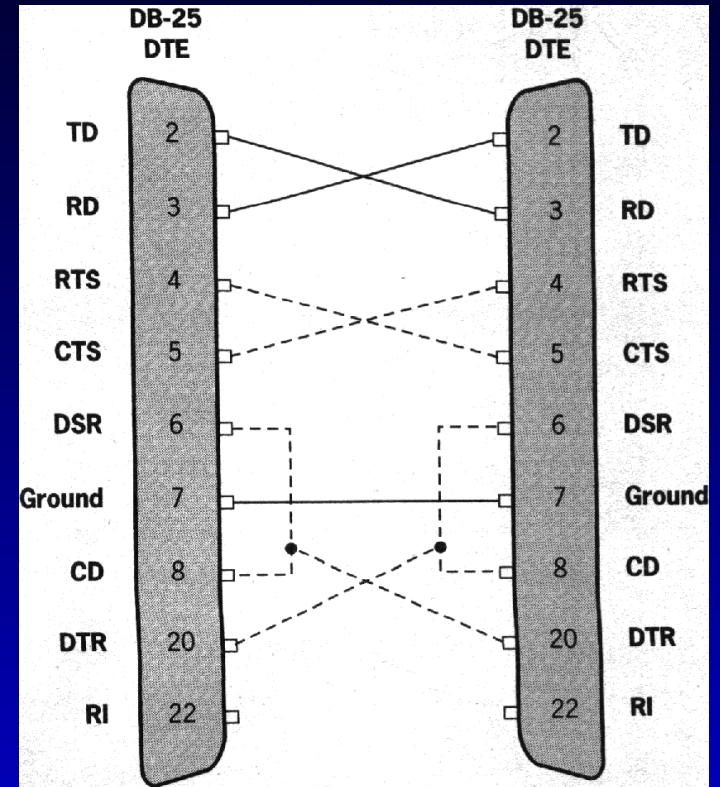

Null-modem

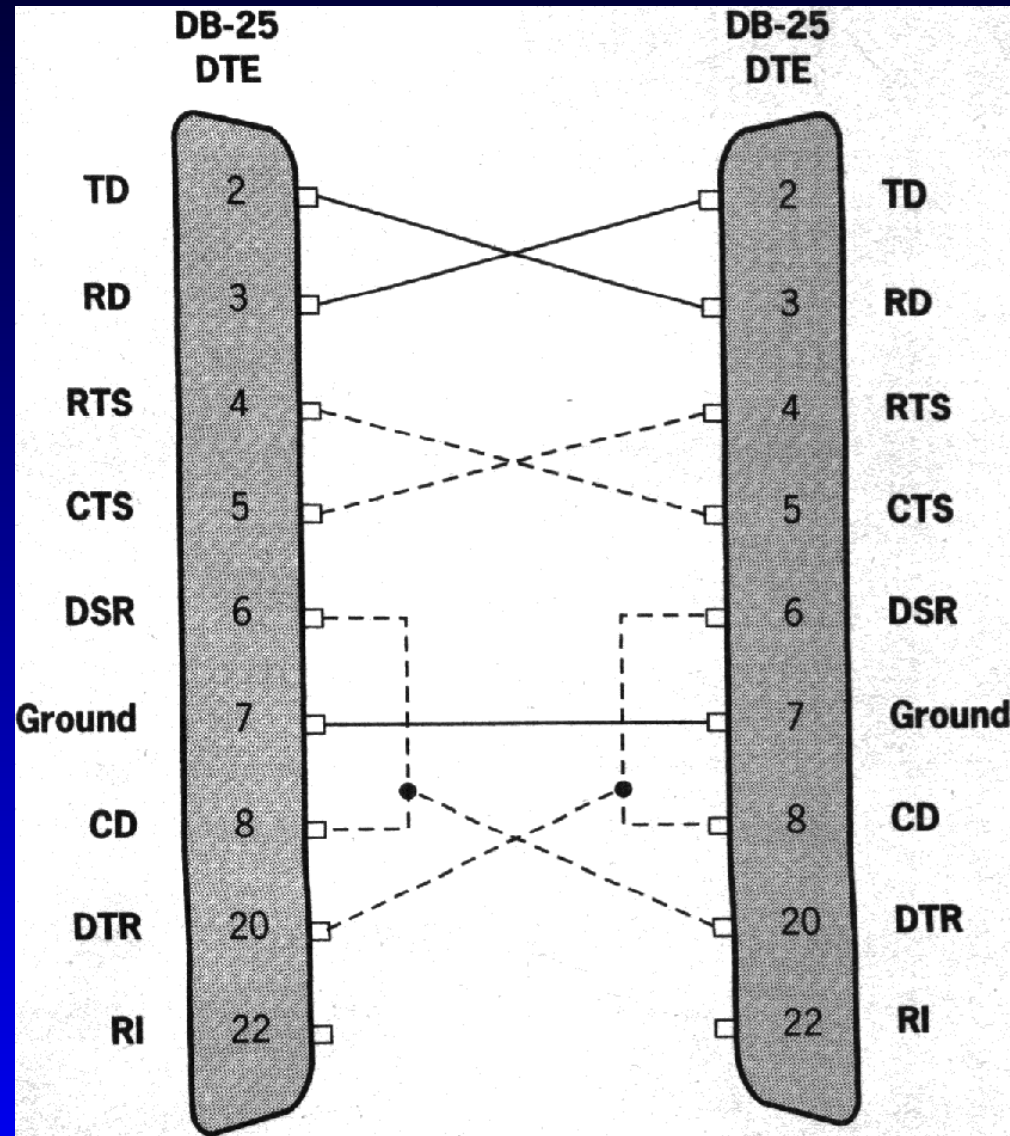



Porta Serial no PC

- As portas seriais do PC são formadas por
 - UART - 8250/14550/16550A
 - Sinais em 0-5V
 - Cristal de 1.8432 MHz
 - Out2 habilita interrupções
 - Drivers TTL/RS-232 - 1488
 - Converte a saída da UART para níveis RS-232
 - Drivers RS-232/TTL - 1489
 - Converte os sinais RS-232 para 0-5V
- Teste sem plug de teste testa apenas a UART

Porta Serial no PC

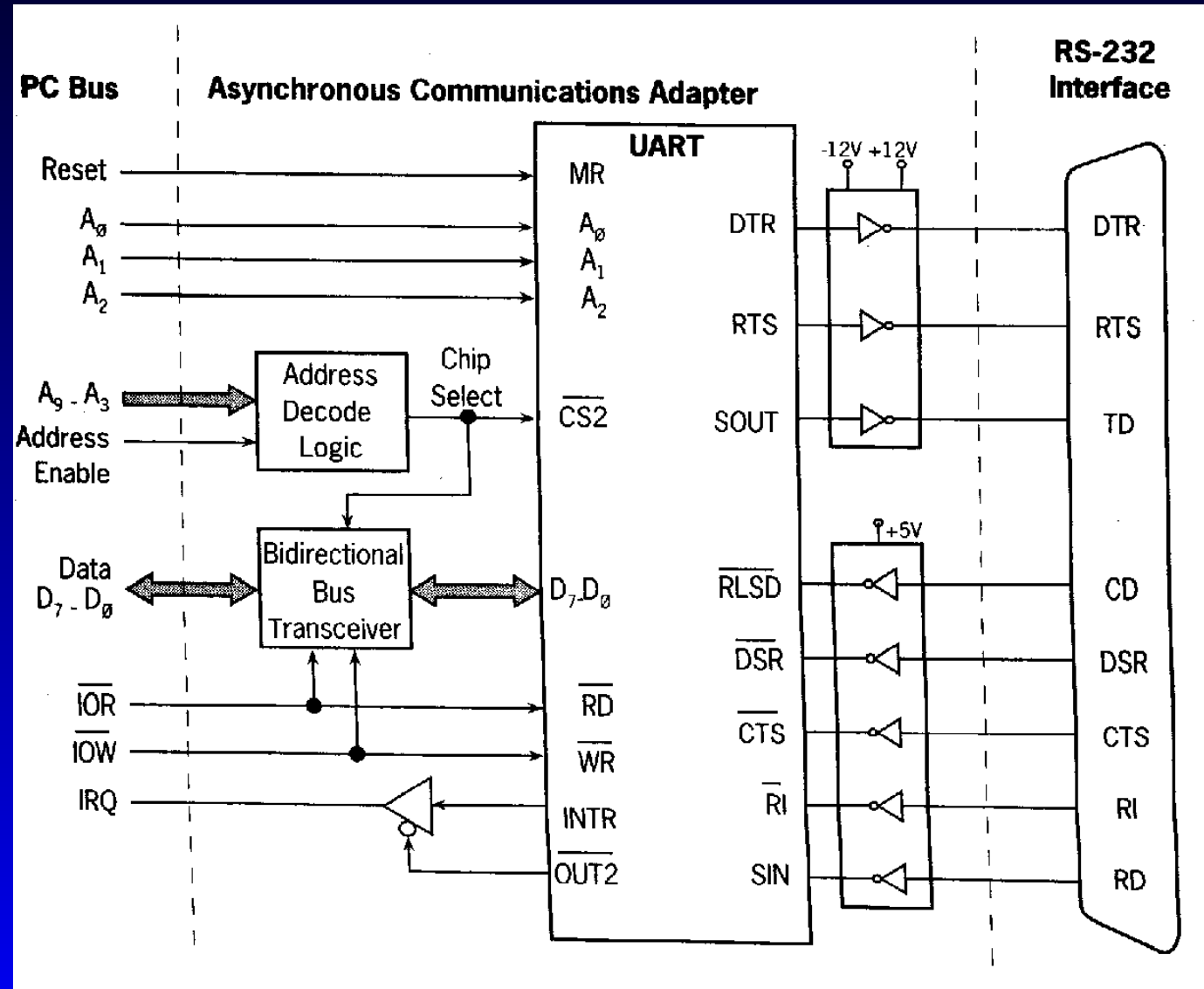



UARTs Utilizados no PC

- 8250
 - Suporta taxas até 38400 bps
- 14450
 - Suporta taxas até 115200
- 16550
 - Inclui FIFOs de 16 bytes
 - Possui *bug* no tratamento das FIFOs
 - Suporta DMA
- 16550A
 - 16550 sem *bug*

Diagrama de Blocos da UART

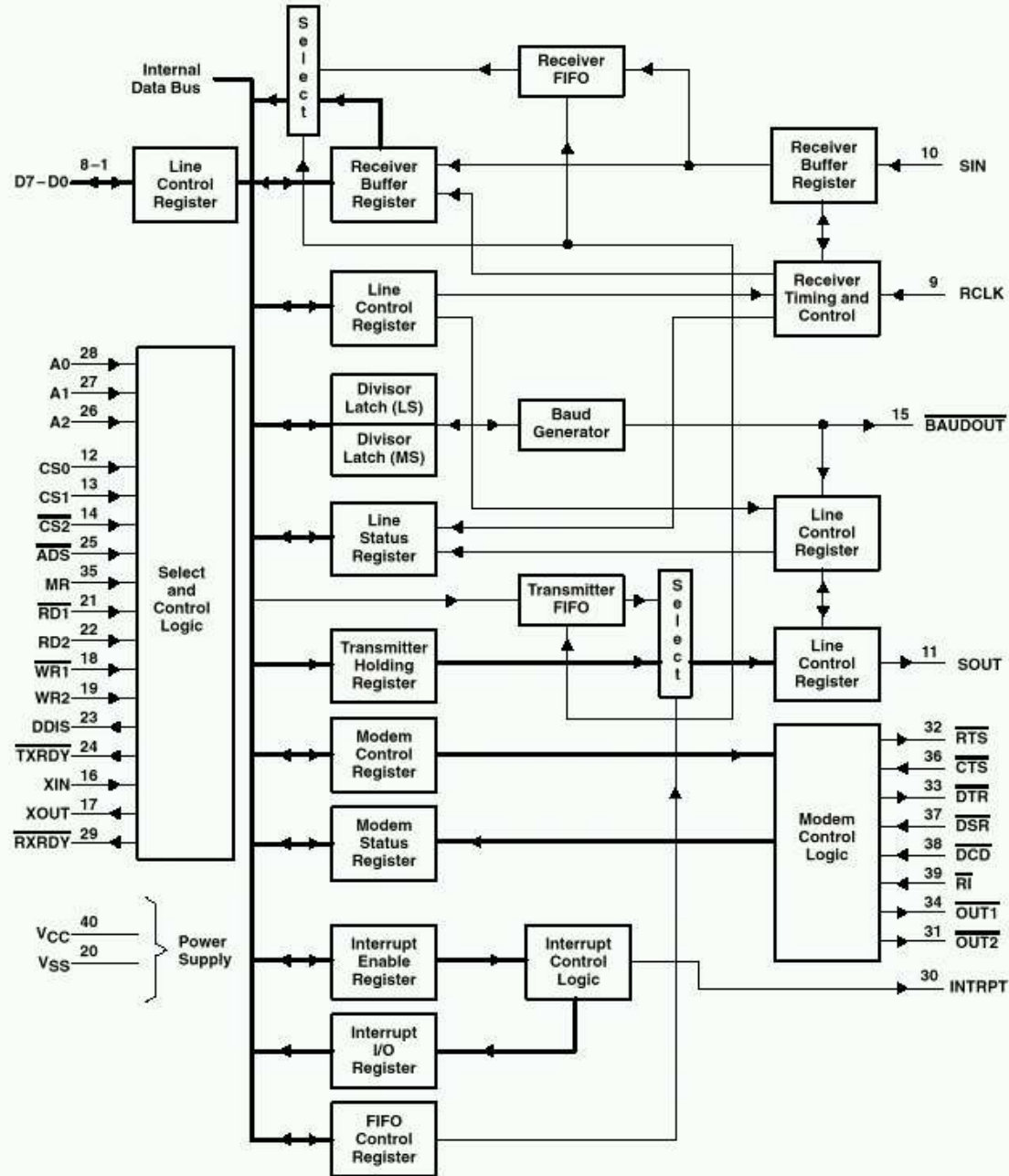



Pinagem

D0	1	40	V _{CC}
D1	2	39	$\overline{\text{RI}}$
D2	3	38	$\overline{\text{DCD}}$
D3	4	37	$\overline{\text{DSR}}$
D4	5	36	$\overline{\text{CTS}}$
D5	6	35	$\overline{\text{MR}}$
D6	7	34	$\overline{\text{OUT1}}$
D7	8	33	$\overline{\text{DTR}}$
RCLK	9	32	$\overline{\text{RTS}}$
SIN	10	31	$\overline{\text{OUT2}}$
SOUT	11	30	$\overline{\text{INTRPT}}$
CS0	12	29	$\overline{\text{RXRDY}}$
CS1	13	28	A0
$\overline{\text{CS2}}$	14	27	A1
$\overline{\text{BAUDOUT}}$	15	26	A2
XIN	16	25	$\overline{\text{ADS}}$
XOUT	17	24	$\overline{\text{TXRDY}}$
$\overline{\text{WR1}}$	18	23	DDIS
WR2	19	22	RD2
V _{SS}	20	21	$\overline{\text{RD1}}$



UART

- Taxa de transmissão determinada por divisor programável de 16 bits
 - Taxa = $1.8432\text{MHz} / 16 / \text{divisor programável}$
- Inserção de start bit, stop bit e paridade
- Linhas de controle de modem
 - CTS, RTS, DSR, DTR, RI e DCD
- Interrupções de transmissão, recepção, estado da linha e dados
- Detecção de erros de paridade, overrun e framing



UART

- Caracteres de 5, 6, 7 ou 8 bits
- Geração e detecção de paridade par, ímpar ou sem paridade
- Geração de 1, 1 1/2 ou 2 stop-bit
- Devido ao cristal utilizado pode-se ter taxas de informação de até 115200bps
 - Existem extensões utilizando cristais de frequência maior
 - Software "descalibrado"

Registadores do 16550A



Bit No.	REGISTER ADDRESS											
	0 DLAB = 0	0 DLAB = 0	1 DLAB = 0	2	2	3	4	5	6	7	0 DLAB = 1	1 DLAB = 1
	Receiver Buffer Register (Read Only)	Transmitter Holding Register (Write Only)	Interrupt Enable Register	Interrupt Ident. Register (Read Only)	FIFO Control Register (Write Only)	Line Control Register	Modem Control Register	Line Status Register	Modem Status Register	Scratch Register	Divisor Latch (LSB)	Latch (MSB)
	RBR	THR	IER	IIR	FCR	LCR	MCR	LSR	MSR	SCR	DLL	DLM
0	Data Bit 0†	Data Bit 0	Enable Received Data Available Interrupt (ERB)	"0" If Interrupt Pending	FIFO Enable	Word Length Select Bit 0 (WLS0)	Data Terminal Ready (DTR)	Data Ready (DR)	Delta Clear to Send (ΔCTS)	Bit 0	Bit 0	Bit 8
1	Data Bit 1	Data Bit 1	Enable Transmitter Holding Register Empty Interrupt (ETBEI)	Interrupt ID Bit 0	Receiver FIFO Reset	Word Length Select Bit 1 (WLS1)	Request to Send (RTS)	Overrun Error (OE)	Delta Data Set Ready (ΔDSR)	Bit 1	Bit 1	Bit 9
2	Data Bit 2	Data Bit 2	Enable Receiver Line Status Interrupt (ELSI)	Interrupt ID Bit (1)	Transmitter FIFO Reset	Number of Stop Bits (STB)	Out1	Parity Error (PE)	Trailing Edge Ring Indicator (TERI)	Bit 2	Bit 2	Bit 10
3	Data Bit 3	Data Bit 3	Enable Modem Status Interrupt (EDSSI)	Interrupt ID Bit (2) (Note 4)	DMA Mode Select	Parity Enable (PEN)	Out2	Framing Error (FE)	Delta Data Carrier Detect (ΔDCD)	Bit 3	Bit 3	Bit 11
4	Data Bit 4	Data Bit 4	0	0	Reserved	Even Parity Select (EPS)	Loop	Break Interrupt (BI)	Clear to Send (CTS)	Bit 4	Bit 4	Bit 12
5	Data Bit 5	Data Bit 5	0	0	Reserved	Stick Parity	0	Transmitter Holding Register (THRE)	Data Set Ready (DSR)	Bit 5	Bit 5	Bit 13
6	Data Bit 6	Data Bit 6	0	FIFOs Enabled (Note 4)	Receiver Trigger (LSB)	Set Break	0	Transmitter Empty (TEMT)	Ring Indicator (RI)	Bit 6	Bit 6	Bit 14
7	Data Bit 7	Data Bit 7	0	FIFOs Enabled (Note 4)	Receiver Trigger (MSB)	Divisor Latch Access Bit (DLAB)	0	Error in RCVR FIFO (Note 4)	Data Carrier Detect (DCD)	Bit 7	Bit 7	Bit 15



Registradores do 16550A

Base+0	Receiver buffer register
	Transmitter holding register
	Divisor latch LSB
Base+1	Interrupt enable register
	Divisor latch MSB
Base+2	Interrupt identification register
Base+3	Line control register
Base+4	Modem control register
Base+5	Line status register
Base+6	Modem status register
Base+7	Scratch register

Receiver Buffer Register (RBR)

- Base+0, DLAB=0, Leitura

Bit	RBR
0	D0
1	D1
2	D2
3	D3
4	D4
5	D5
6	D6
7	D7



Transmitter Holding Register (THR)

- Base+0, DLAB=0, Escrita

Bit	THR
0	D0
1	D1
2	D2
3	D3
4	D4
5	D5
6	D6
7	D7



Divisor Latch LSB (DLL)

- Base+0, DLAB=1

Bit	DLL
0	D0
1	D1
2	D2
3	D3
4	D4
5	D5
6	D6
7	D7



Interrupt Enable Register (IER)

- Base+1, DLAB=0

Bit	IER
0	Habilita interrupção quando dado disponível
1	Habilita interrupção quando THR vazio
2	Habilita interrupção de estado da linha
3	Habilita interrupção de estado do modem
4	0
5	0
6	0
7	0

Divisor Latch MSB (DLM)

- Base+1, DLAB=1

Bit	DLM
0	D8
1	D9
2	D10
3	D11
4	D12
5	D13
6	D14
7	D15



Interrupt Identification Register (IIR)

- Base+2, Leitura

Bit	IIR
0	0 se interrupção pendente
1	Identificação de interrupção IID0
2	Identificação de interrupção IID1
3	Identificação de interrupção IID2
4	0
5	0
6	FIFO habilitado
7	FIFO habilitado



Interrupt Identification

IIR3	IIR2	IIR1	Prioridade	Interrupção
0	0	0	nenhuma	nenhuma
0	1	1	1	estado da linha de RX
0	1	0	2	dado disponível
1	1	0	2	time-out de caractere
0	0	1	3	THR vazio
0	0	0	4	estado do modem

FIFO Control Register (FCR)

- Base+2, Escrita



Bit	FCR
0	Habilitação das FIFOs
1	Reseta FIFO de recepção
2	Reseta FIFO de transmissão
3	Seleciona modo DMA
4	Reservado
5	Reservado
6	Nível da FIFO de RX (LSB)
7	Nível da FIFO de RX (MSB)



FIFO Trigger Level

IIR7	IIR6	Nível de disparo
0	0	1
0	1	4
1	0	8
1	1	14

Line Control Register (LCR)

- Base+3



Bit	LCR
0	Seleciona tamanho de palavra
1	Seleciona tamanho de palavra
2	Número de stop bits
3	Habilita paridade
4	Seleciona paridade par
5	Seleciona paridade <i>stick</i>
6	Ativa break
7	DLAB



Word Length & Stop Bits

LCR1	LCR0	Tamanho de palavra
0	0	5
0	1	6
1	0	7
1	1	8

LCR2	palavra	Stop bits
0	qualquer	1
1	5 bits	1 1/2
1	6 bits	2
1	7 bits	2
1	8 bits	2

Modem Control Register (MCR)

- Base+4



Bit	MCR
0	DTR
1	RTS
2	Out 1
3	Out 2
4	Loop
5	0
6	0
7	0

Line Status Register (LSR)

- Base+5



Bit	LSR
0	Dado pronto
1	Erro de <i>overrun</i>
2	Erro de paridade
3	Erro de quadro
4	Break detectado
5	THR vazio
6	Transmissor vazio
7	Erro na FIFO de RX

Modem Status Register (MSR)

- Base+6



Bit	MSR
0	Δ CTS
1	Δ DSR
2	Borda final de RI
3	Δ DCD
4	CTS
5	DSR
6	RI
7	DCD



Scratch Register (SCR)

- Base+7

Bit	SCR
0	D0
1	D1
2	D2
3	D3
4	D4
5	D5
6	D6
7	D7

Line Driver 1488

- Conversor TTL/RS-232

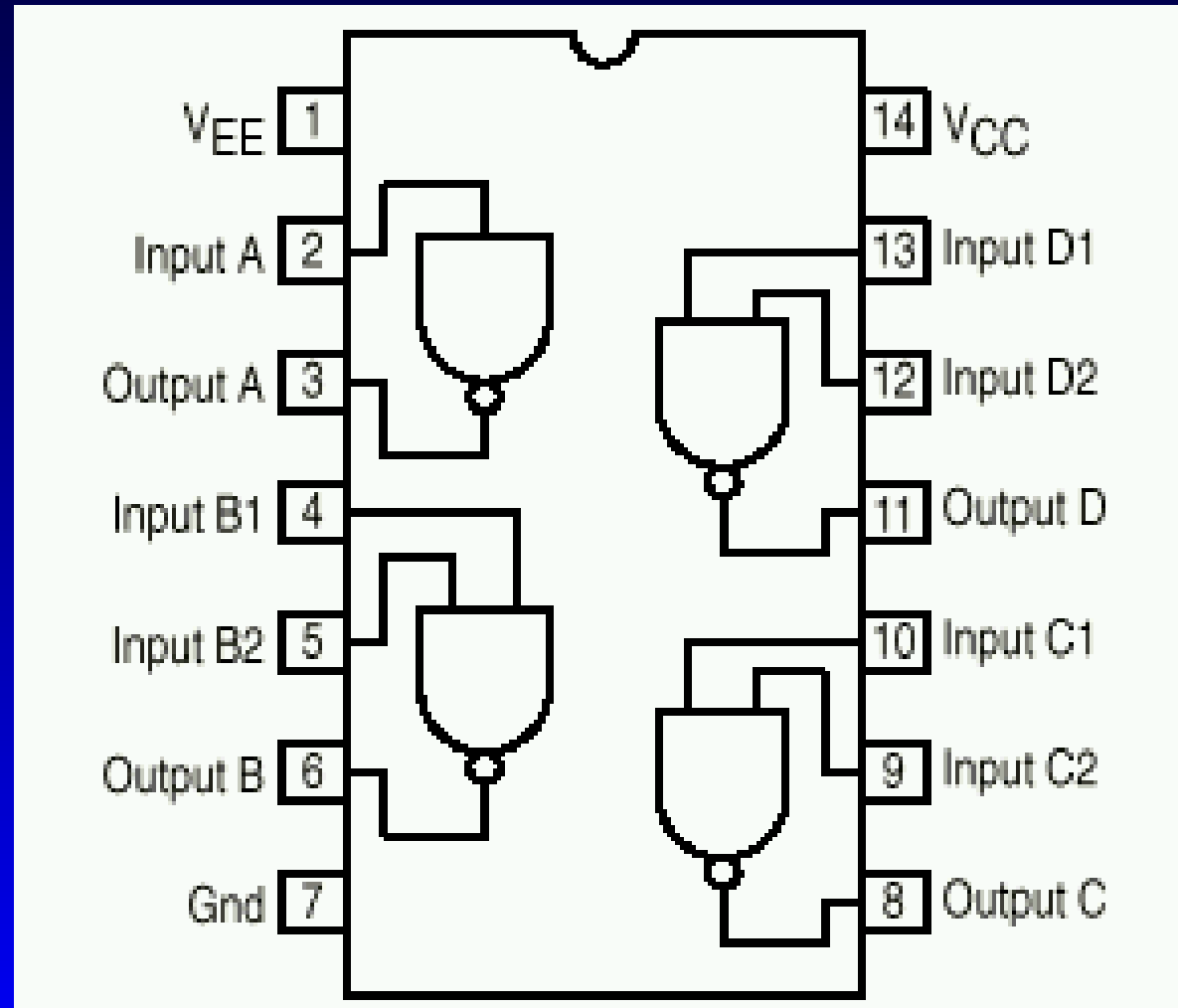

Line Receiver 1489

- Conversor RS232/TTL

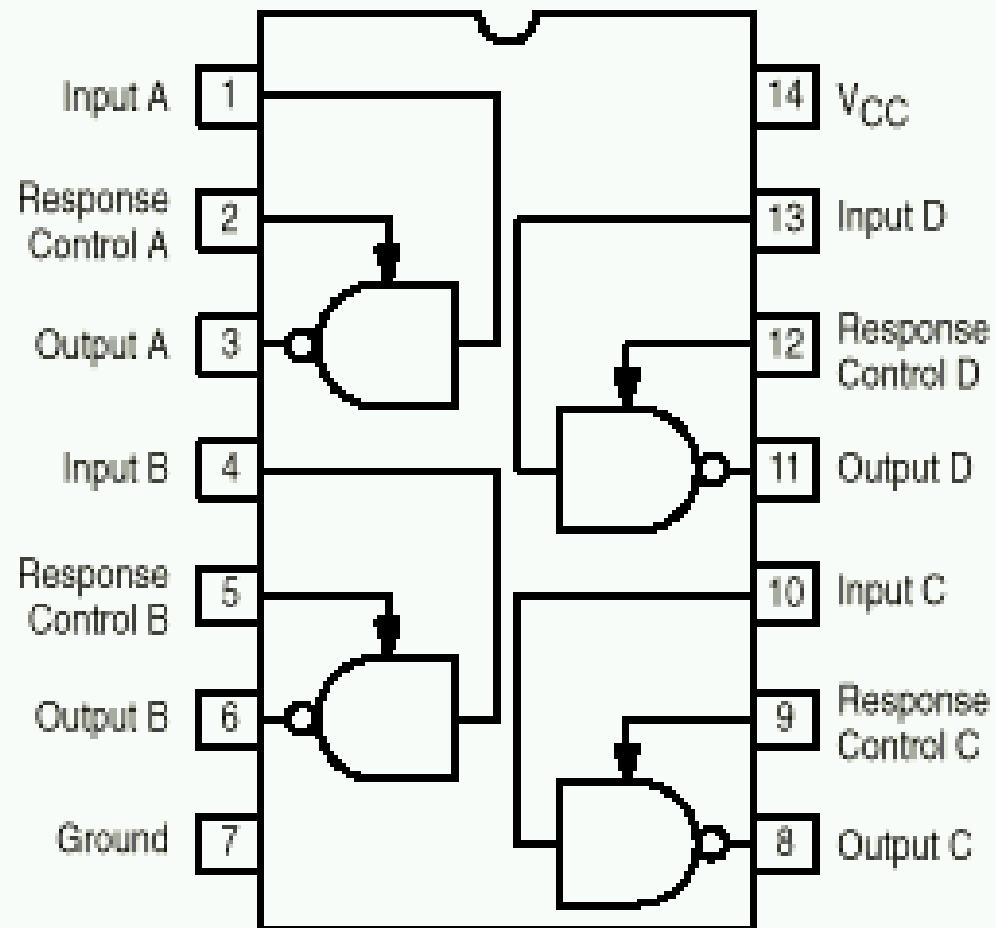



Endereços no PC

- Um PC pode ter até 4 portas seriais
 - No POST a BIOS armazena os endereços das portas paralelas encontradas na área de dados da BIOS
 - 0040:0000H** endereço base de COM1
 - 0040:0002H** endereço base de COM2
 - 0040:0004H** endereço base de COM3
 - 0040:0006H** endereço base de COM4
- Cada porta serial ocupa 8 portas de I/O



Endereços Padrão no PC

- Normalmente as portas seriais utilizam os seguintes endereços base
 - 3F8H
 - Normalmente utilizada com IRQ4
 - 2F8H
 - Normalmente utilizada com IRQ3
 - 3E8H
 - Normalmente utilizada com IRQ4
 - 2E8H
 - Normalmente utilizada com IRQ3
- A BIOS procura pelas portas na ordem acima
 - A primeira encontrada é COM1, a segunda COM2, a terceira COM3 e a quarta COM4



Exercício

- Fazer um programa para transmitir dados a 9600 bps 8N1
- Fazer um programa para receber dados a 9600 bps 8N1